

Model TOUCAN 12E PLUS

MAST BOOM LIFTS



MORE ECONOMIC

- Electric power for zero emissions and near-silent running indoors.

MORE PRODUCTIVE

- No waiting with immediate-response AC drive motors for greater torque and efficiency.

MORE ACCESS

- Get into more places with compact dimensions and precise control system.

SMART DESIGN

- Extended reach and up-and-over height with heavy duty forklift-style mast and versatile articulating jib.

Standard Features

- 0.70 m x 1.05 m (L x W) steel platform
- Slide bar rear entry
- Full proportional drive and slew joystick control with integral thumb steer switch
- Mini joysticks provide proportional mast, telescope and jib lift/lower functions
- 4.14 m articulating jib
- Function enable with enlarged LCD function status display
- Load sensing system
- AC power cable to platform
- Large tool tray
- Two wheel direct electric drive
- Brushless AC drive motors
- Powered battery fill
- Auto power save when idle
- Low charge function cut-out
- On-board diagnostics with integral display
- Automatic rear wheel brakes
- Sculptured polyester hoods
- Powered platform rotation
- Heavy duty steel roller mast with 345° rotation
- Chain slack detection system
- 3 degree tilt alarm and indicator light
- 1.20 m wide frame
- Lifting /tie down rings
- Ground control selector switch with key lock
- Battery discharge indicator
- Hour meter
- Horn
- Drive orientation system
- Lanyard anchor points
- Zenon strobe light
- Manual descent system
- Passive pothole protection system

Standard Specifications

- | | |
|-----------------------------|-----------------------|
| • Tyres (non-marking solid) | 457mm x 178mm |
| • Electrical system | 48V DC |
| • Batteries (deep cycle) | 48V - 260 A/hr |
| • Charger | On-board 110V/230V HF |
| • Drive motors | Dual AC motors |
| • Electrical (pump) motor | 3.5kw - 48V DC |
| • Hydraulic system | 15L |

Accessories & Options

- 8 mm air line to platform
- 255A/hr AGM Battery & on board HF charger
- LED Platform worklight
- Food Compatible Hydraulic Oil
- Platform Power Plug & Socket ¹
- Soft Touch 0.70 m x 1.05 m Platform Proximity System
- Synthetic Biodegradable Hydraulic Oil
- Obstacle detection frame
- Special paint colour
- Fixed (non-rotating) platform
- Platform work lights 70W



¹ Included with circuit breaker on AC cable to platform option. NB 110V or 230V power must be specified

Model TOUCAN 12E PLUS

MAST BOOM LIFTS

Performance

- Working height 12.65m
- Working outreach (standard platform) 6.05m
- Up and over height 7.12m
- Swing (not continuous) 345°
- Platform capacity ¹ 200 kg
- Jib - overall length 4.14m
- Jib - range of articulation 120° (+60° / -60°)
 - A. Platform size standard platform (L x W) 0.70m x 1.05m
 - B. Overall width 1.20m
 - C. Tailswing 13cm
 - D. Stowed height 1.99m
 - E. Overall length (standard platform) 3.65m
 - F. Wheelbase 1.60m
 - G. Ground clearance 10cm
- Machine weight - standard platform ² 4,900 kg
- Maximum ground bearing pressure 14,0 kg/cm²
- Drive speed - lowered 6.0 km/h
- Turning radius (outside) 2.60m
- Turning radius (inside) 0.75m
- Gradeability 30%

¹ Capacity shown is maximum two persons indoor and outdoor (12.5 m/s wind speed)

² Certain options or country standards may increase weight and/or dimensions.

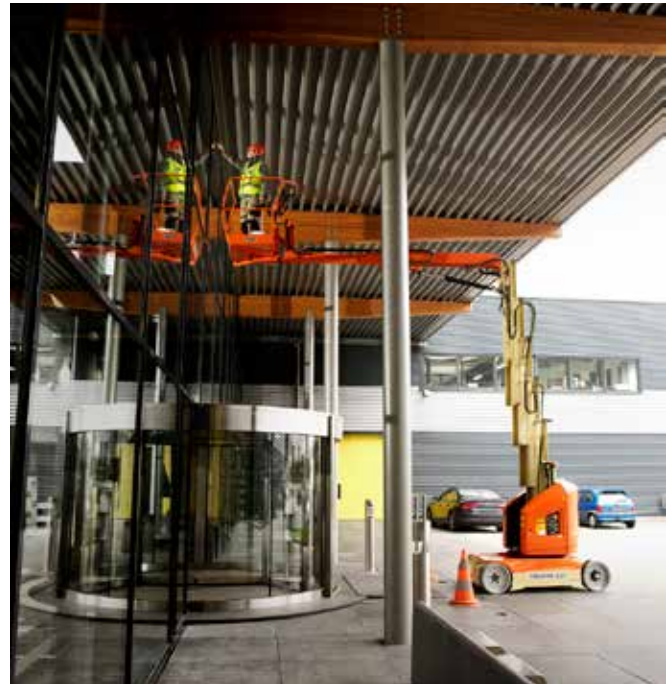

Reach Diagram

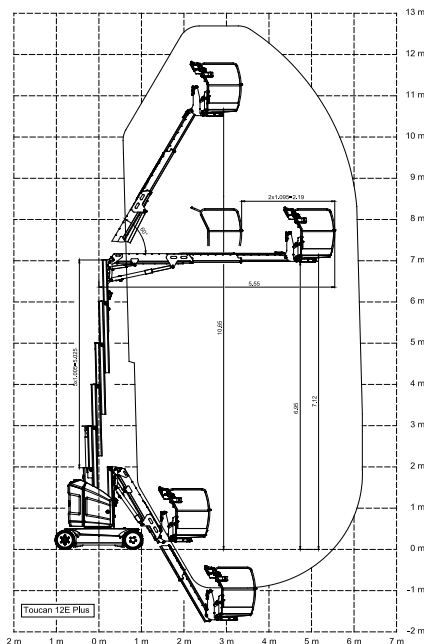

Dimensions

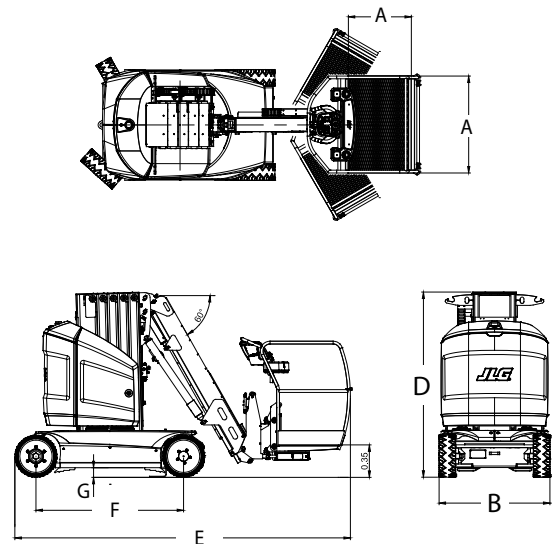

IMPORTANT

JLG is continually researching and developing products and reserves the right to make modifications without prior notice. All data in this document is indicative. Certain options or country standards will increase weight. Specifications may change to meet country standards or with the addition of optional equipment.

Due to continuous product improvements, JLG Industries reserves the right to make specification and/or equipment changes without prior notification.



JLG EMEA BV

Polaris Avenue 63
2132 JH Hoofddorp
The Netherlands
Phone: +31 (0)23 565 5665
www.jlg.com

An Oshkosh Corporation Company